

**MADE IN
FRANCE**

CATALOGUE N° 160.11



MAROLO

491

**WORKSHOP
EQUIPMENT**



OUTBOARD ENGINE STAND SM 150

SM 150

USABLE WITH



CAPACITY

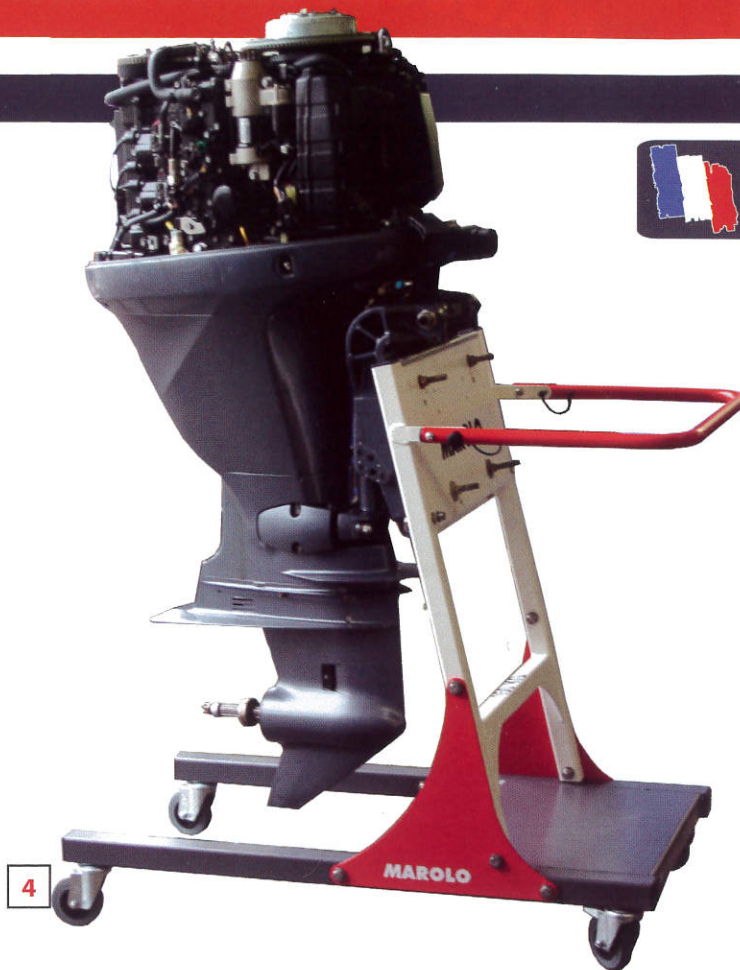

- Stainless steel deck 1
- Stainless steel screws 2
- Retractable handling bar 3
- 4 directional wheels with 2 wheels braked 4
- Tool box (option) 5



OPTION : TOOL BOX - STEP

Ref. 900212

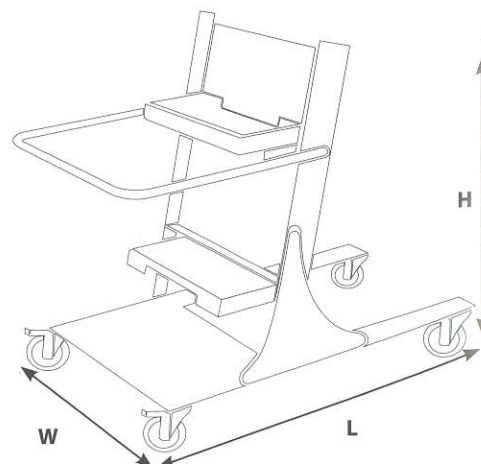

SPECIFICATIONS

MODEL	Ref.	H	L	W	CAPACITY	TOOLBOX / STEP	WEIGHT
SM 150	900215	1080 mm	1100 mm	600 mm	150 Kg	OPTION	75 Kg

Tel. +33 (0)2 41 29 29 29 - Email. contact@marolotest.com

MAROLO

OUTBOARD ENGINE STAND SM 450

SM 450

USABLE WITH



CAPACITY



- Sliding stainless steel deck 1
- Stainless steel screws 2
- Step / Tool box (one supplied & option) 3
- Retractable handling bar 4
- Front & lateral steps in aluminium checker plate 5
- 4 wheel steering with 2 wheels braked 6
- Lateral stabilizers (option) 7



MAROLO STAND

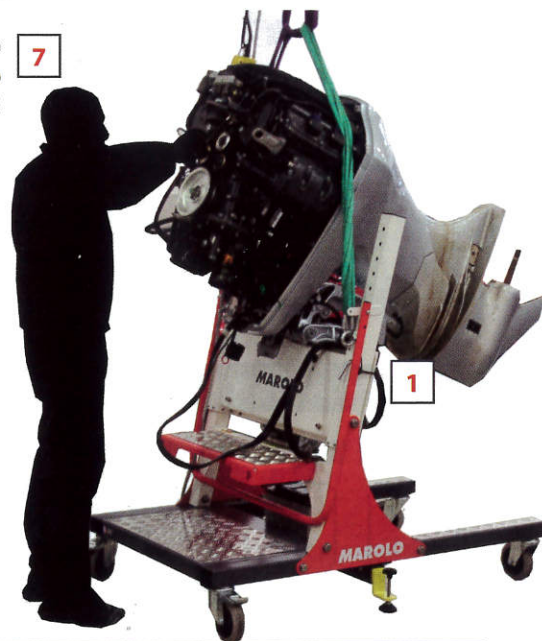
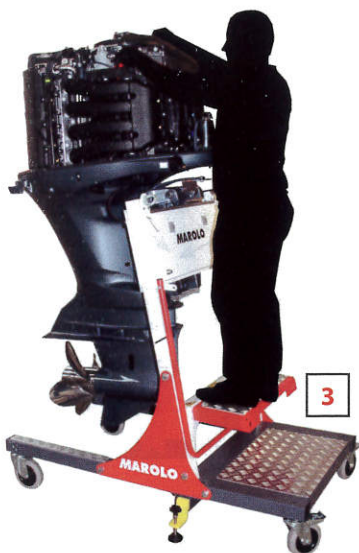

OPTION : TOOL BOX - STEP

Ref. 900212

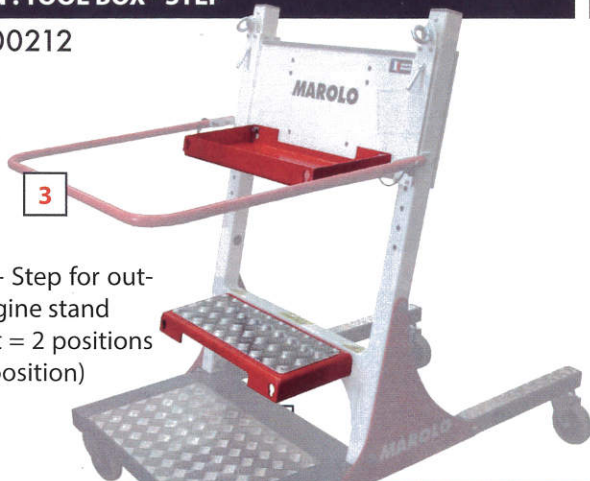

Tool box - Step for outboard engine stand
1 product = 2 positions
(reverse position)

STABILIZERS FOR OUTBOARD ENGINE STAND SM 450

Ref. 900211



SPECIFICATIONS

MODEL	Ref.	H	L	W	CAPACITY	TOOLBOX / STEP	WEIGHT
SM 450	900210	1400 mm	1450 mm	800 mm	450 Kg	1	150 Kg

LOWER UNIT STAND

LOWER UNIT STAND - SE 50

USABLE WITH



CAPACITY



- U with plastic protection **1**
- Rotating U 360° **2**
- 2 quick fixing systems with protection **3**
- Drip tray (option) **4**

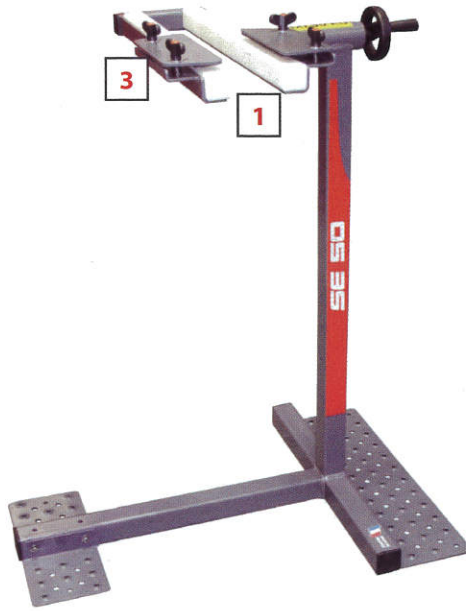

OPTION : DRIP TRAY

Ref. 900222



SPECIFICATIONS

MODEL	Ref.	H	L	W	CAPACITY	WEIGHT
SE 50	900220	1040 mm	810 mm	610 mm	50 Kg	37 Kg

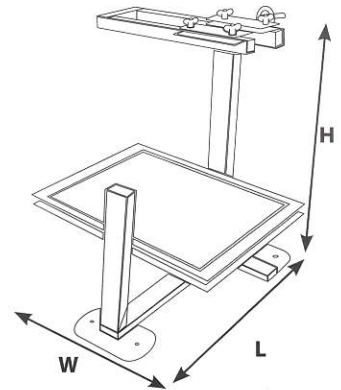

OUTBOARD STORAGE RACK - SM 500

USABLE WITH



CAPACITY

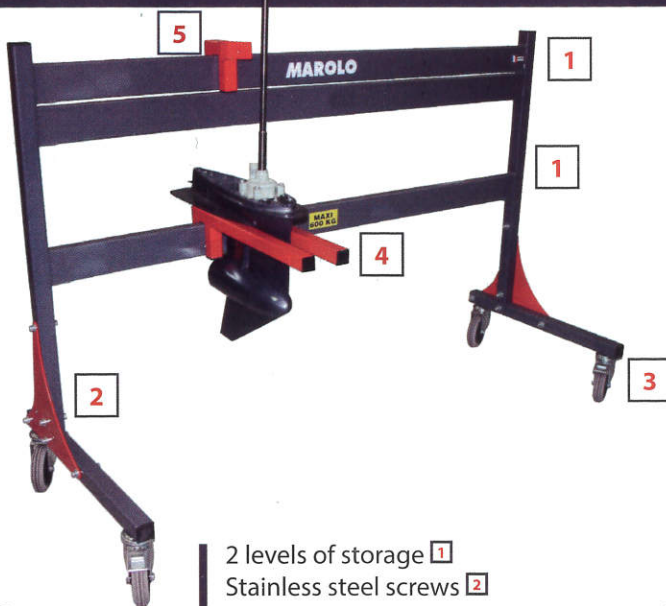

OPTION : LOWER UNIT BRACKET (X2)

Ref. 900231

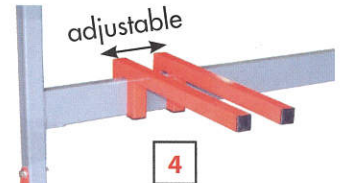

OPTION : V BRACKET FOR STERN DRIVE

Ref. 900232

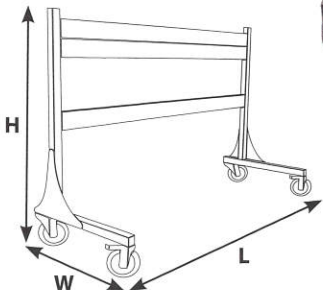
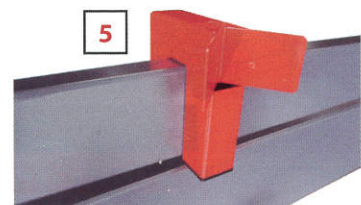

- 2 levels of storage **1**
- Stainless steel screws **2**
- 4 wheel steering wheels with 2 wheels braked **3**
- Adjustable lower unit bracket - capacity 100 kg (option) **4**
- V bracket for stern drive (option) **5**

SPECIFICATIONS

MODEL	Ref.	H	L	W	CAPACITY	WEIGHT
SM 500	900230	1335 mm	2000 mm	760 mm	500 Kg	100 Kg

Tel. +33 (0)2 41 29 29 29 - Email. contact@marolotest.com

MAROLO

STERNDRIVE JACK

STERNDRIVE JACK

USABLE WITH



CAPACITY



4 axis
Designed for heavy-duty use
Wheels for irregular floors **1**

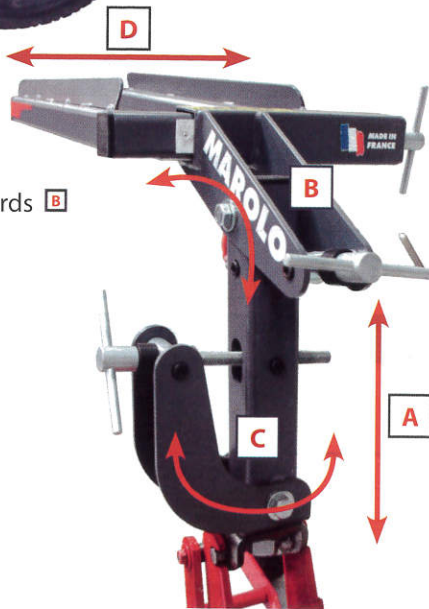

4 axes :
UP - Down **A**
Tilt forwards and backwards **B**
Tilt left - right **C**
Sterndrive clamp **D**

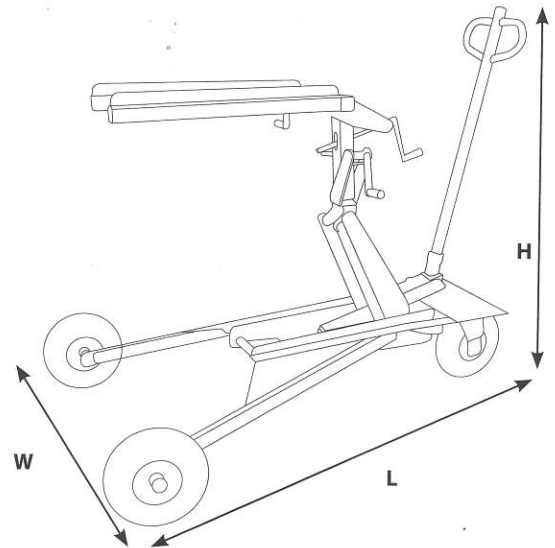

SPECIFICATIONS

MODEL	Ref.	H USEFULL		L	W	CAPACITY	WEIGHT
		H mini	H maxi				
STERNDRIVE	900240	1020 mm	700 mm	1400 mm	820 mm	200 Kg	37 Kg

TXB EVO

Ref. 800204
includes
software
800201



1

IDC4 SOFTWARE

Ref. 800201



3

Multibrand diagnostic tools, usable with outboard engines, inboard engines, jet ski / watercraft **1**
Designed for internal and external use
TXB terminal is connected to engine calculator by specific wires **2**
TXB terminal is connected by bluetooth to personal computer
Very easy to use - Interactive software **3**
All the brands below are included in the software
Wires can be bought individually

All the brands included in the software
Computer not included



Outboard engines

YAMAHA MARINE	EVINRUDE	HONDA MARINE	SUZUKI MARINE	JOHNSON	MARINER	MERCURY	MERCURY RACING
---------------	----------	--------------	---------------	---------	---------	---------	----------------

Inboard engines

CUMMINS MERCUISER DIESEL	FNM MARINE	FPT (FIAT POWERTRAIN TECHNOLOGIES)	ILMOR	INDMAR	MERCUISER	MERCURY RACING	PCM MARINE ENGINES
PERKINS	SEA-DOO	SISU	STEYR MOTORS	VOLKSWAGEN MARINE	VOLVO PENTA	YANMAR	

Jets ski / Water craft

HONDA MARINE	KAWASAKI MARINE	SEA-DOO (BRP)	YAMAHA MARINE				
--------------	-----------------	---------------	---------------	--	--	--	--

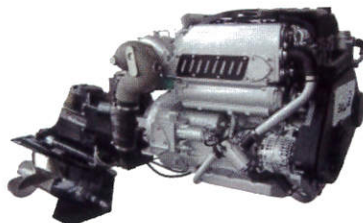

WORKBENCHE, STORAGE & CRANE

METAL WORKBENCHES

Drawers with key locking system & with ball-bearing rails



OPTION: CARPET RUBBER

Ref. 801321



SPECIFICATIONS

MODEL	Ref.	H	L	W	NUMBER OF FOOT	WEIGHT
WORK BENCH 1,5	801310	880 mm	1500 mm	640 mm	4	73 Kg
WORK BENCH 2	801305		2000 mm		6	93 Kg

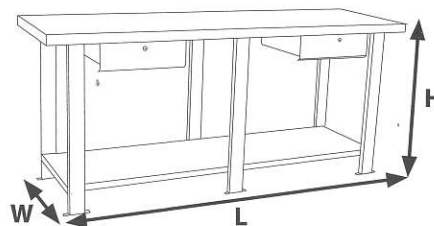

TOOL STORAGE PANEL

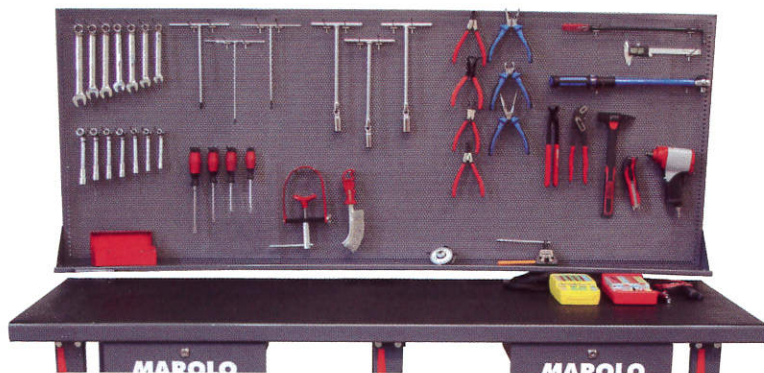

Tools not included

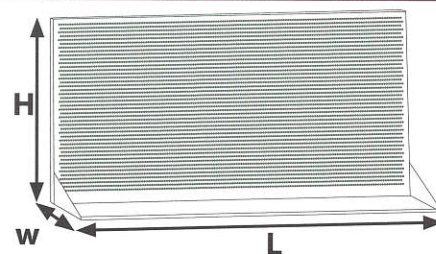

SPECIFICATIONS

MODEL	Ref.	H	L	WEIGHT
TOOL STORAGE PANEL 1,5	801312	830 mm	1500 mm	7 Kg
TOOL STORAGE PANEL 2	801330		2000 mm	9 Kg

ADDICRANE

CAPACITY



Capacity : 250 kg or 500 kg
Chain hoist, électric hoist or manual winch with safety brake 1
4 directional wheels with 2 braked 2

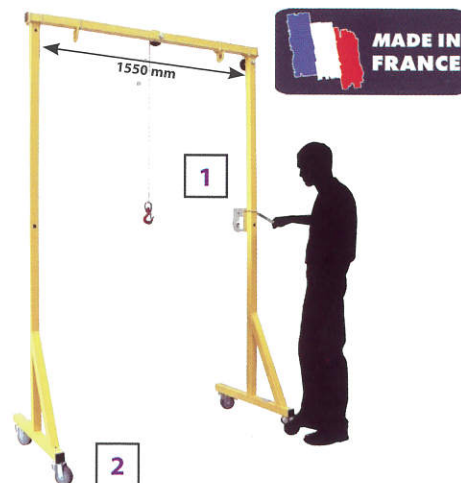
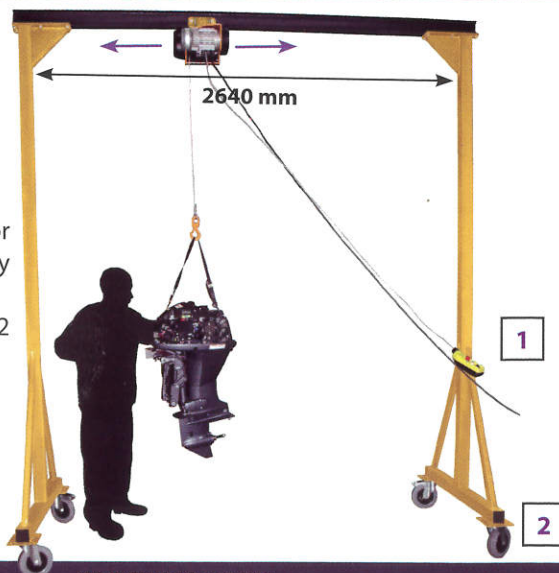

SPECIFICATIONS

MODEL	Ref.	H	L	W	CAPACITY	WEIGHT
ADDICRANE 250 - WINCH	801427	2480 mm	1700 mm	800 mm	250 Kg	90 Kg
ADDICRANE 500 - CHAIN HOIST	801585	3500 mm	3300 mm	1250 mm	500 Kg	115 Kg
ADDICRANE 500 - ELECTRIC HOIST	801587					135 Kg

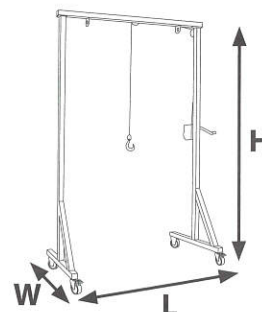

MAROLO

Tel. +33 (0)2 41 29 29 29 - Email. contact@marolotest.com

MAROLO KIT

CLEANING SOLUTION

BIOLOGICAL FOUNTAINS MAROLOBIO

MAROLO BIO



MAROLOBIO 100

Heavy-duty use
 Workshop washing machine
 Without solvent ⇒ without risk
 Washing solution cleaned by bacteria ⇒ auto-recycling to keep washing solution a long time (≈12 to 24 months)
 Very efficient to wash hydrocarbon dirty (grease, oil, resin...) on mechanical parts



Ref. 400112

Biodegradable degreaser
 Without toxic or dangerous products
 Non-flammable and odourless
 Can of 20 litres



Ref. 400113

Pill of micro-organisms to regenerate the Maroloclean solution

Warning: To have effective microorganisms, the bath should be heated to 38°C and oxygenated

1 Pill must be added every 4 to 6 weeks

Box of 4 pills



MAROLOBIO 80

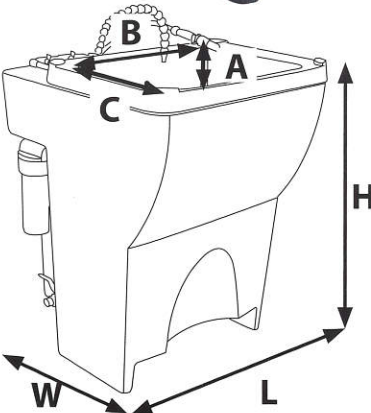

SPECIFICATIONS / SPECIFICHE TECNICHE / TECHNISCHE EIGENSCHAFTEN

MODEL	Ref.	FOUNTAIN DIMENSIONS			SINK DIMENSIONS			SINK CAPACITY	ENERGY	WEIGHT
		H	L	W	A	B	C			
Marolobio 80	801254	970 mm	770 mm	750 mm	200 mm	600 mm	420 mm	125 Kg	Single phase 230 V - 50 Hz	47 Kg
Marolobio 100	801255	1080 mm	940 mm	880 mm	200 mm	750 mm	450 mm	150 Kg		62 Kg

ULTRASOUND TANK

Heavy-duty use
 Supplied with basket and cover
 Frequency of ultrasounds : 28 kHz
 Ideal frequency for cleaning mechanical parts



Before



After

Before



After



SPECIFICATIONS

MODEL	Ref.	ULTRASOUND			BASKET			CAPACITY	ENERGY	HEATING	WEIGHT
		H	L	W	H	L	W				
ULTRASOUND TANK 10 L	801241	280 mm	500 mm	170 mm	150 mm	500 mm	130 mm	250 Kg	Electric 230 V - 50 Hz - 300 W	Yes, automatic	17 Kg
ULTRASOUND TANK 18 L	801211	395 mm	480 mm	340 mm	150 mm	480 mm	290 mm	500 Kg	Electric 230 V - 50 Hz - 600 W	Yes, adjustable from 0 to 65 °C	21 Kg

MAROLO

MAROLOTEST

Boulevard du Cormier - Parc d'activités du Cormier

B.P. 20753 - 49307 CHOLET cedex - FRANCE

Tél. 33 (0)2 41 29 29 29 - Fax : 33 (0)2 41 29 29 30

Email : contact@marolotest.com - Web : www.marolotest.com